

DEVELOPMENT OF HIGH PRECISION BEAM POSITION MONITOR READOUT SYSTEM WITH NARROW BANDPASS FILTERS FOR THE KEKB INJECTOR LINAC TOWARDS THE SUPERKEKB

R. Ichimiya[#], K. Furukawa, F. Miyahara, M. Satoh, T. Suwada
KEK, Tsukuba, Japan

[#] (e-mail: ryo@post.kek.jp)

SuperKEKB accelerator complex

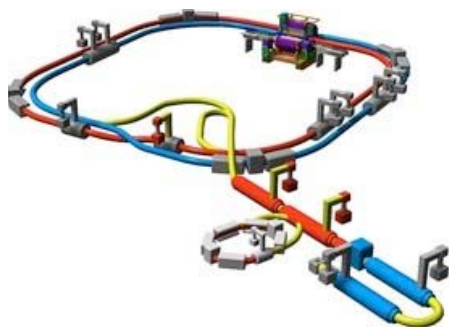

Existing system (oscilloscope)

- 100 BPMs are read out by ~20 readout system.
- 10 Gsa/s oscilloscope as a waveform digitizer.
- Two scope's channels with different attenuation are used for wide dynamic range input.
- ~50 μm position resolution.
- EPICS IOC is running on scope's WinXP.

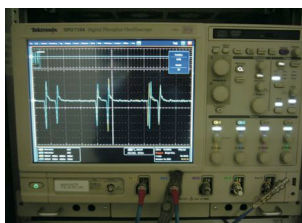

Tektronix DPO7104 (10 Gsa/s 4 ch, 8 bit, 50 Hz trigger operation)

Block diagram

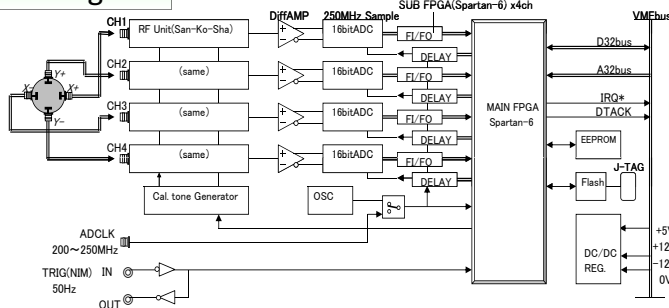

Beam Test

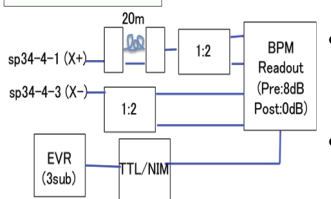

- Using beam signal, ideal (no beam-jitter) two-bunch beam (for X-axis) is emulated.
- 100 events (at 0.45 nC /bunch) taken.

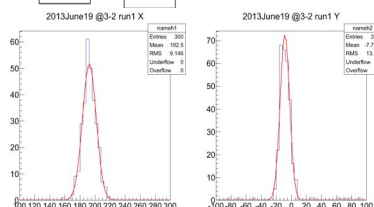

Position Resolution	1st	2nd
ch1, 2(X)	5.7 μm	8.2 μm
ch3, 4(Y)	5.1 μm	

(preliminary)

SuperKEKB specifications

- World highest luminosity: $L=8 \times 10^{35} / \text{cm}^2/\text{s}$
 - 40 times brighter than KEKB
- Positron dumping ring
- 8-GeV injector linac, in each 20ms (50Hz), injects e^- and e^+ into
 - KEKB high-energy ring (HER): **7 GeV, 5 nC, 20 mm mrad e^-**
 - at KEKB, 8GeV, 1nC, 100 mm mrad e^-
 - KEKB low-energy ring (LER): **4 GeV, 4 nC, 10 mm mrad e^+**
 - Positron primary: **4 GeV, 10 nC e^-**
 - at KEKB, 3.5GeV, 1nC, 2100 mm mrad e^+
- Photon Factory (PF): **2.5 GeV, 0.1nC e^-**
- PF-AR (single bunch mode PF): **3.0GeV, 0.1nC e^-**
- Accelerator structures have to align within ± 0.1 mm accuracy.
- BPM are required to have *one magnitude better position resolution*:
 - < 10 μm position resolution.

New system



- VME-based system
 - 1 board for 1 BPM
- Narrow bandpass filter (BPF) under sampling type.
 - 16-bit 250MSa/s ADC
 - $F_c=300$ MHz (3rd Nyquist Zone: 250-375MHz)
 - Two Bessel filters with helical-coils.
- Accepts 96 ns interval two bunches.
- Two electrical attenuators for high dynamic range input.
- Measured position drifts are compensated by on-board calibration.
 - Between the beam cycle, calibration tones are output to the BPM electrodes to determine the inter-channel gain imbalance.
- Position/Charge calculations are performed with on-board FPGA.

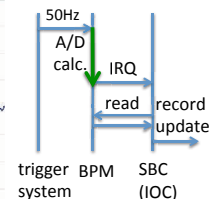
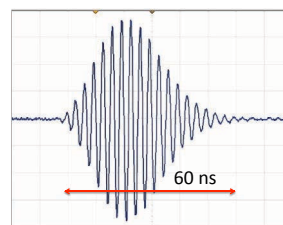
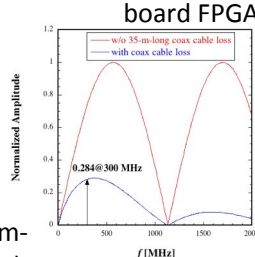

Summary and future plan

- Achieved target position resolution (< 10 μm) and design refining for final prototype is underway.
- New readout system will be installed at 2014 summer shutdown.
- EPICS IOC, timing system implementation.